

# System Bypass Design Considerations and Recommendations for Variable Flow Chilled Water, Hot Water and Simultaneous Heating & Cooling Systems

## CHILLER/HEATER SYSTEM BYPASS

Commonly Asked Questions:

### Do I need a bypass at the chiller/heater system?

Yes, a bypass is required for any chilled water/evaporator, hot water/condenser (heating load) and source water side (geothermal, cooling tower or closed circuit cooler) with variable pumping. The bypass must be piped in such a way that the temperature and differential pressure sensors are still sensing active flow.

Figure 1 – Field Piping Direct Return

Figure 1 – Field Piping Direct Return – 1 to 5 modules

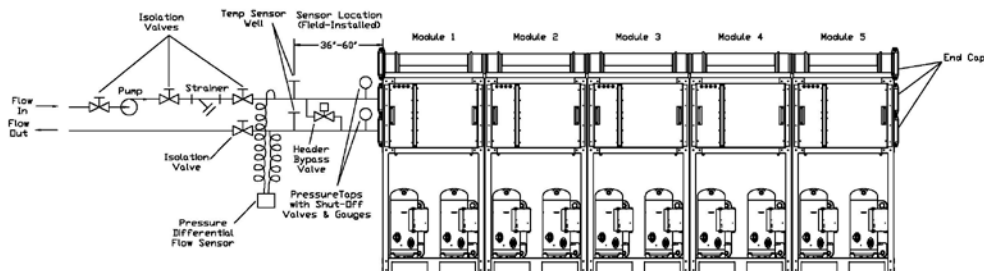

\*Header bypass valve may be installed at either end of the bank.

### What is the purpose of the chiller/heater system bypass?

The purpose of the chiller/heater system bypass is to prevent deadheading of the pumps when all of the internal unit valves go closed as well as allow temperature and differential pressure sensors to sense active flow.

## Can the chiller/heater system be utilized as a bypass?

Yes, modules can be designated for fixed bypass for heating, cooling and source flow, however, this limits the number of modules remaining for that duty. For instance with an SHC OnDemand® heat pump system with four (4) modules, if you designate one (1) module for heating bypass and one (1) module for cooling bypass, the system now only allows a maximum of three (3) modules for heating or three (3) modules for cooling.

## What amount of flow should the chiller/heater system bypass be sized for?

The bypass should be sized for an absolute minimum of one module's worth of design flow. Refer to selection software for design flow rates.

## Can I purchase a chiller/heater system bypass kit from ClimaCool?

Yes, you can purchase a bypass kit from ClimaCool. The kits are inexpensive, easy to install and controls are integrated with the ClimaCool CoolLogic software.

Figure 2 – Direct Return 6" HEADERS

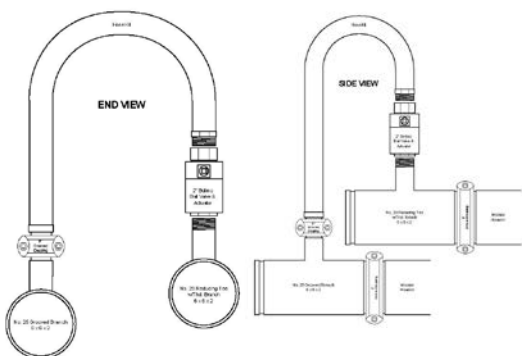

Figure 3 – Reverse Return 6" HEADERS

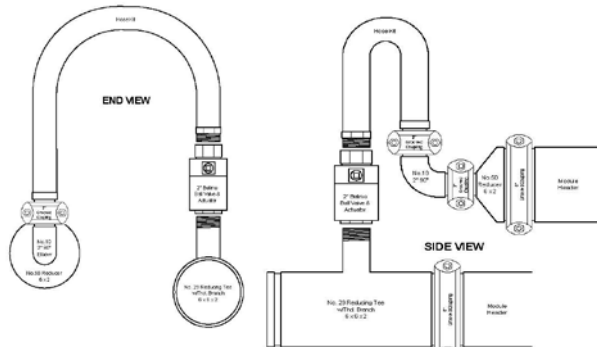

Figure 2 – Direct Return 8" HEADERS

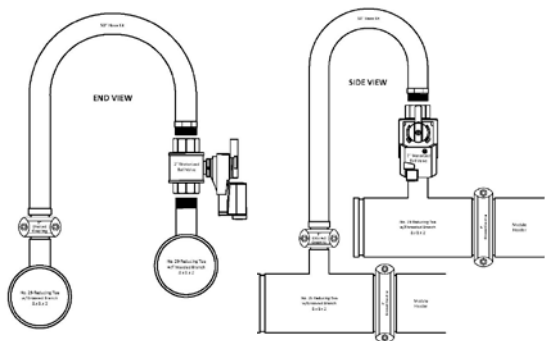
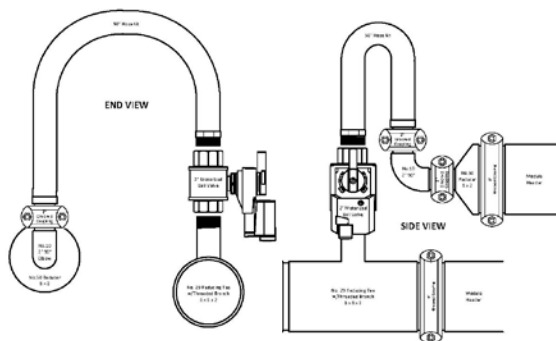

Figure 3 – Reverse Return 8" HEADERS



### **Can a chiller/heater system bypass be created with field supplied piping?**

Yes, the design piping must accommodate one module's worth of design flow, and be positioned so that the temperature and differential flow sensors sense active flow in the bypass mode. Refer to the Water Piping Configuration Drawing, Figure 1, on previous page.

### **How is the field supplied piping chiller/heater system bypass controlled?**

The field supplied piped chiller/heater system bypass must be controlled by others. It may control the differential pressure across the chiller/heater system, gpm flow meters, etc.

### **Can the ClimaCool *CoolLogic* controls via BACnet or other remote interface be utilized to control a field supplied bypass?**

No. There are system communication delays, polling and network conflicts that strictly prohibit the use of ClimaCool sensors and controls for control of field supplied bypasses or other field installed items. The recommended method is to control via differential pressure or gpm flow meters across the chilled water/evaporator, hot water/condenser and source water systems.

The above strictly relates to the bypass at the chiller/heater system. In order to have a stable operating cooling and/or heating system, consideration must be given to the load side of the system as well.

### **LOAD SIDE SYSTEM BYPASS (AIR HANDLER, FAN COILS, etc.)**

Commonly Asked Questions:

#### **Is a bypass required at the load side of the system?**

Yes, a load system bypass is required for preventing pump deadheading, allowing active flow system sensing and preventing starving flow from the chiller/heater system.

#### **What are some examples of an acceptable load side system bypass?**

- Utilize a quantity of 3-way control valves on the largest loads farthest from the chiller/heater system.
- Field piping with a control valve to provide a bypass across the larger system loads when their 2-way valves go closed.

Figure 4 – Typical Load Bypass Valve Arrangement

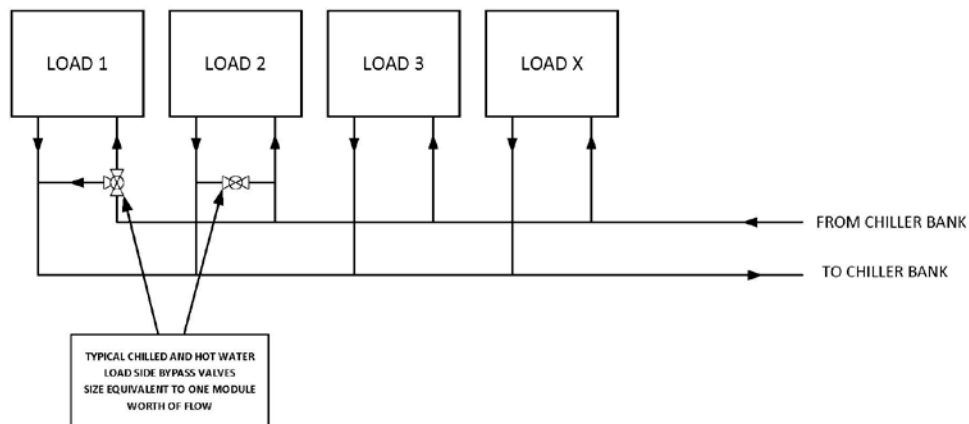

**What amount of flow should the load side system bypass be sized for?**

The system should be sized for an absolute minimum of one module’s worth of design flow. Refer to selection software for design flow rates.

**Is there a required minimum system volume to maintain proper system thermal mass?**

Yes, a minimum of six (6) gallons per nominal system ton are required to maintain proper system thermal inertia. This is to avoid short cycling of compressors in the chiller/heater system as well as prevent nuisance alarms.